



FIRST Project

Introduction

- A project **FIRST**, Specially Promoted Research in Grants-in Aid for Scientific Research by the MEXT has started. Under this project, a heterogeneous multi-computer system **FIRST** cluster is constructed, where a special purpose processor GRAPE is embedded. This is one of HMCS-E systems. We are developing **Blade-GRAPE**, which is a board for full size PCI slot in 2U server PC. In two years, 16×16 PC cluster system will be constructed. With this system, we aim at the elucidation of first generation objects in the universe.

FIRST Cluster

Node: 2U-server with **Blade-GRAPE**

- A special GRAPE board for full size PCI slot named **Blade-GRAPE** is embedded in a 2U-size of 19-inch rack mountable server PC which has dual CPUs in SMP configuration. Each server PC is also equipped with multi-port Gigabit Ethernet NIC to be connected to a special interconnection network with commodity Ethernet switches.

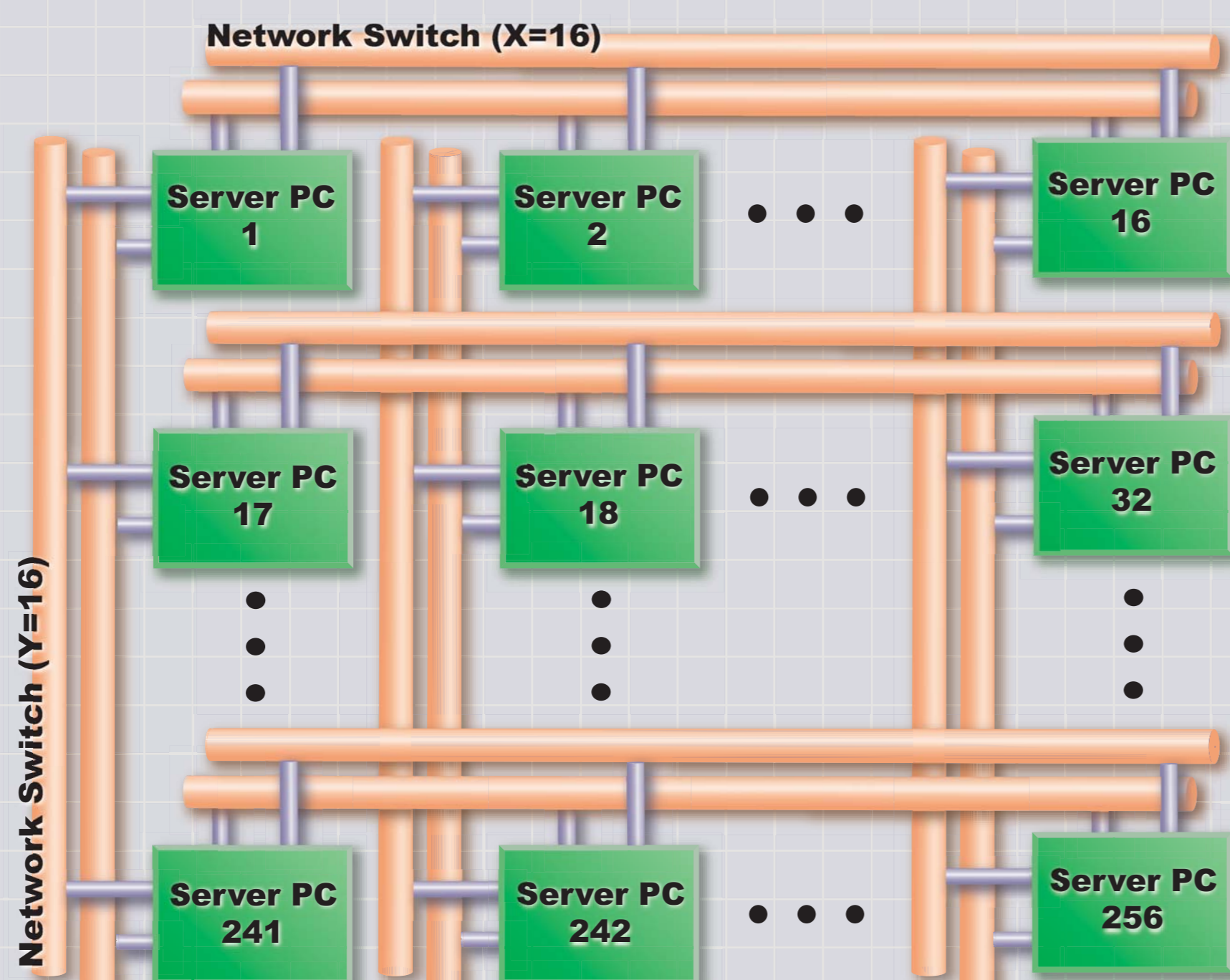
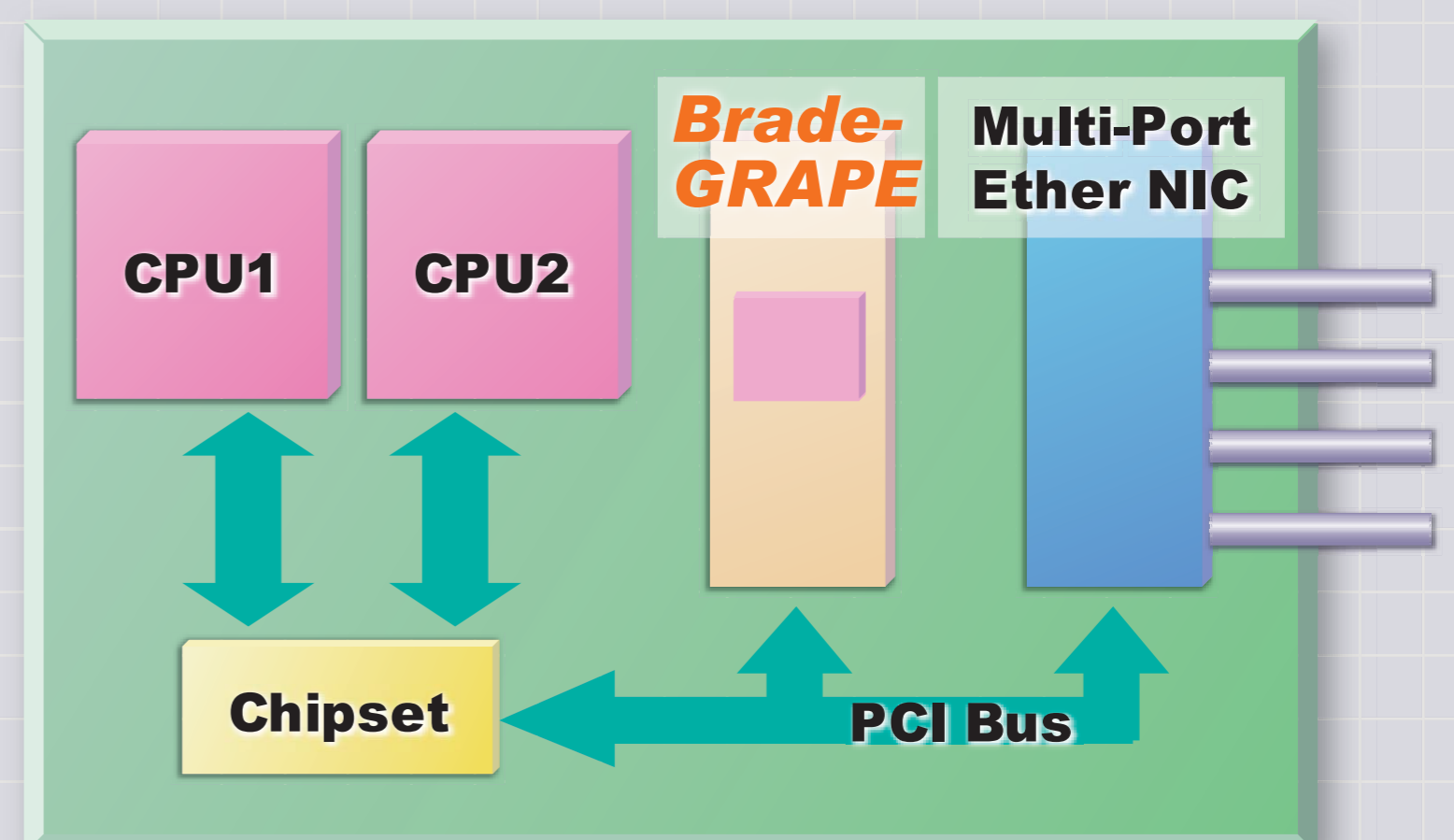

Network: 3-D Hyper Crossbar

- 256 of server PCs (nodes) with 512 CPUs are configured in 16×16 array where all nodes are connected by 2-dimensional Hyper Crossbar Network with commodity switches. Each node is connected to both X and Y dimensions of Ethernet switch, and the message is routed by software at any junction node if necessary. In order to provide high communication bandwidth, each link between a node and a single dimension is doubled by trunk connection of Gigabit Ethernet.